

Images Scientific Instruments Inc
Staten Island NY 10312
718.966.3694 Tel
718.966.3695 Fax
www.imagesco.com

GCK-02 Geiger Counter Kit Manual and Assembly Guide

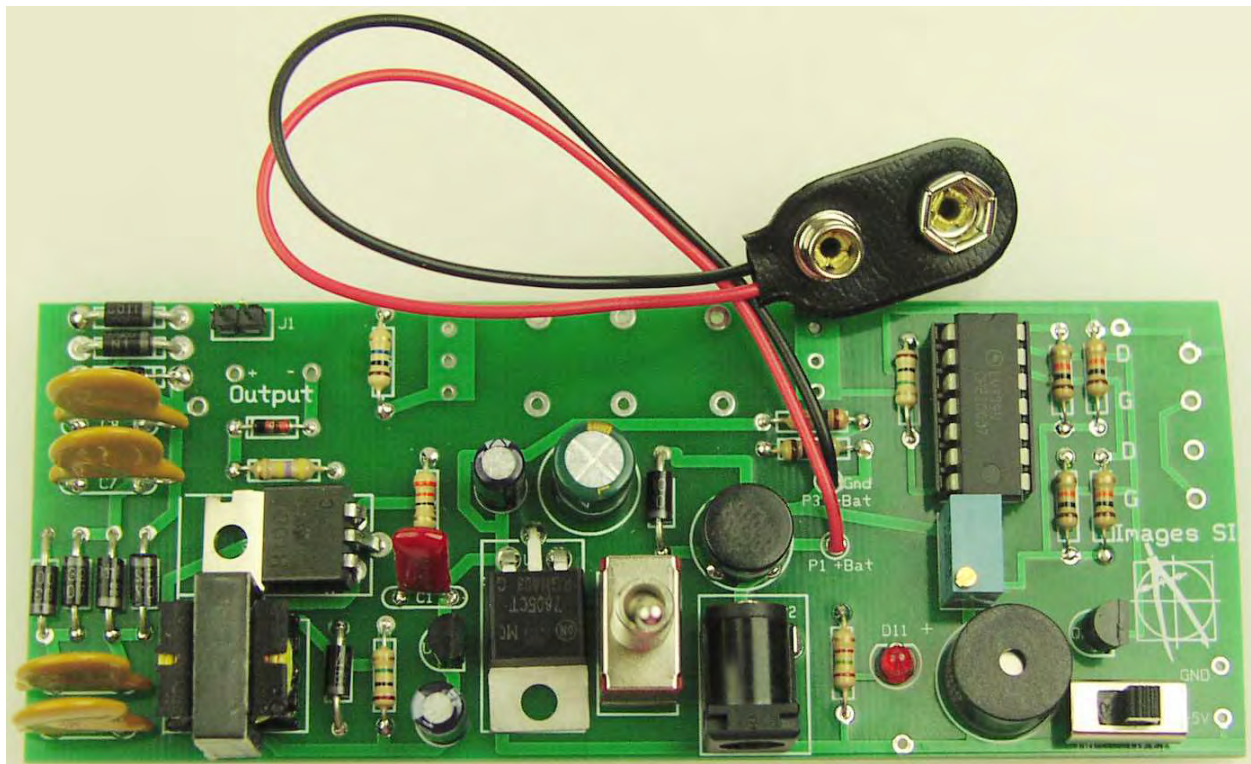

This kit can utilize a variety of GM tubes, so depending upon a GM tube's availability you can choose one that is readily available and in your price range.

Once assembled, this Geiger counter outputs audible click and will blink a LED with each radioactive particle it detects. In addition, it has two digital outputs that may be connected to a number of accessory instruments; a data logger, Digital Meter adaptor that outputs an approximate radiation level, RS-232 adaptor to plot radioactivity on a PC, and true random number generator, in addition to an analog / digital meter adaptor.

What is Radioactivity

Radioactivity is the spontaneous emission of energy from the nucleus of certain atoms. The most familiar radioactive material is uranium.

There are three forms of energy associated with radioactivity; alpha, beta and gamma radiation. The classifications were originally determined according to the penetrating power of the radiation, see figure 1. Depending upon your GM tube selection our Geiger counter can detect the three types of radiation; alpha, beta and gamma radiation.

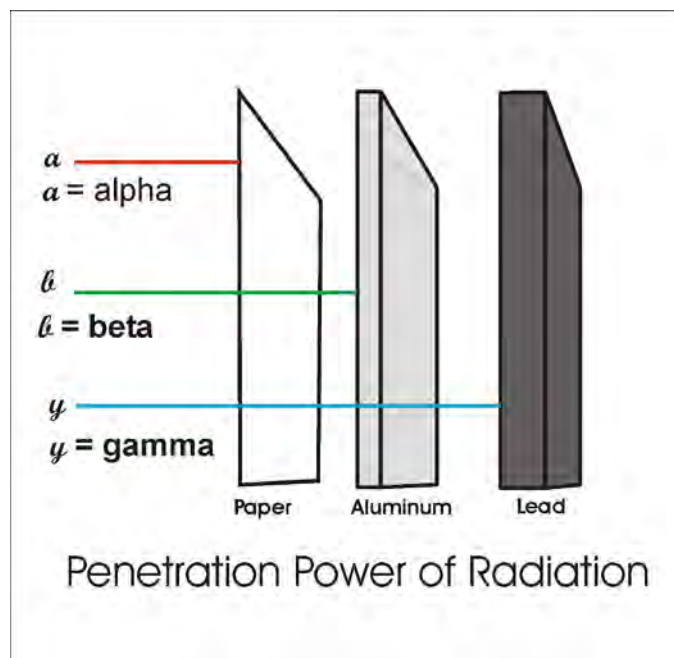

Figure 1

Alpha rays are the nuclei of helium atoms, two protons and two neutrons bound together. Alpha rays have a net positive charge. Alpha particles have weak penetrating ability, a couple of inches of air or a few sheets of paper can effectively block them.

Beta rays were found to be electrons, identical to the electrons found in atoms. Beta rays have a net negative charge. Beta rays have a greater penetrating power than Alpha rays and can penetrate 3mm of aluminum.

Gamma rays are high-energy photons. This has the greatest penetrating power being able to pass through several centimeters of lead and still be detected on the other side. Thick lead is needed to attenuate gamma radiation.

Geiger Mueller Tube

Geiger Mueller tubes are simple devices that detect and measure the intensity of radioactivity. The original design by H. Geiger and E.W. Mueller in 1928 hasn't changed very much. The basic sensor functioning remains the same.

A cut away drawing of a typical Geiger Mueller (GM) tube is shown in figure 2. The wall of the GM tube is a thin metal (cathode) cylinder surrounding a center electrode (anode). The metal wall of the GM tube serves as the cathode of the GM Tube. The front of the tube is a thin Mica window sealed to the metal cylinder. The thin mica window allows the passage and detection of the weak penetrating alpha particles. The GM tube is first evacuated then filled with Neon, Argon plus a Halogen gas.

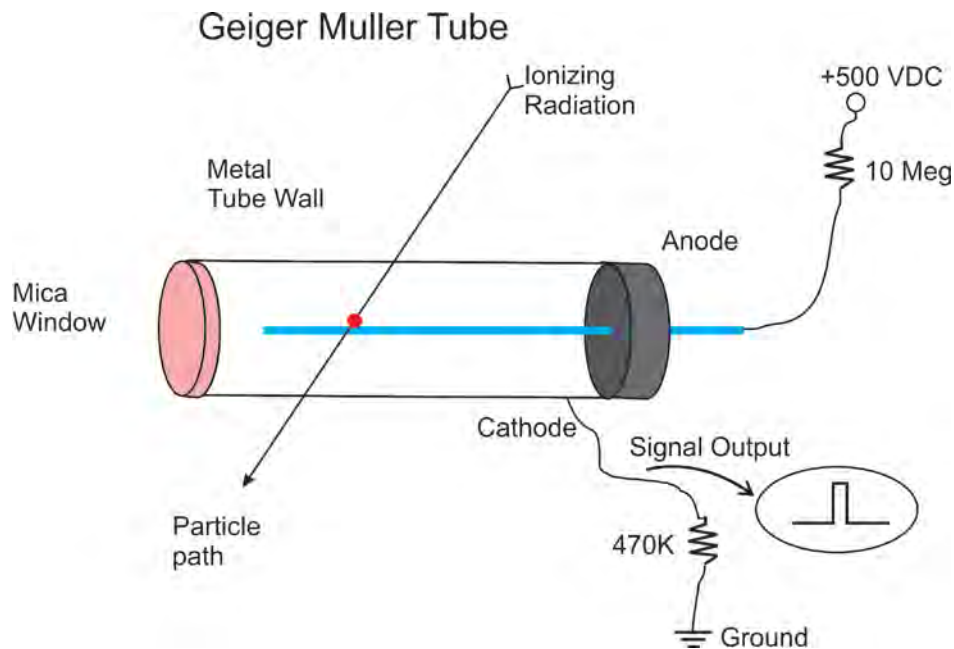

Figure 2

Our GM tube is put into an initial state (ready to detect a radioactive particle), by applying +500-volt potential to the anode (center electrode) through a ten mega ohm current limiting resistor. A 470K-ohm resistor is connected to the metal wall cathode of the tube and to ground. The top of the 470K resistor is where we see our pulse signal whenever a radioactive particle is detected.

In its initial state the GM tube has a very high resistance. However, when a radioactive particle passes through the GM tube, it ionizes the gas molecules in its path and creates a momentary conductive path in the gas. This is analogous to the vapor trail left in a cloud chamber by a particle. In the GM tube, the electron liberated from the atom by the particle, and the positive ionized atom both move rapidly towards the high potential electrodes of the GM tube. In doing so they collide with and ionize other gas atoms, creating a momentary avalanche of ionized gas molecules. And these ionized molecules create a

small conduction path allowing a momentary pulse of electric current to pass through the tube allowing us to detect the particle.

This momentary pulse of current appears as a small voltage pulse across the 470 K ohm resistor. The halogen gas quickly quenches the ionization and the GM tube returns to its high resistance state ready to detect more radioactivity.

Dead Time

For the short amount of time the GM tube is detecting one particle, if another radioactive particle enters the tube it will not be detected. This is called dead time. The maximum dead time for the LND 712 GM tube is 90 microseconds (or .00009 seconds). There is a mathematical formula for adjusting a Geiger counter read out to compensate for the GM tube's dead time. Different GM tubes have different dead times.

Count Rate vs. Dose Rate

Each output pulse from the GM tube is a count. The counts per second give an approximation of the strength of the radiation field. Typically a GM tube is calibrated using either a cesium-137 or colbalt-60 radiation source. The chart is shown in figure 3 is a typical response curve for a generic GM tube. Each GM tube will have its own response curve to radiation. For many of the GM tubes available on Ebay, the response curve is not available.

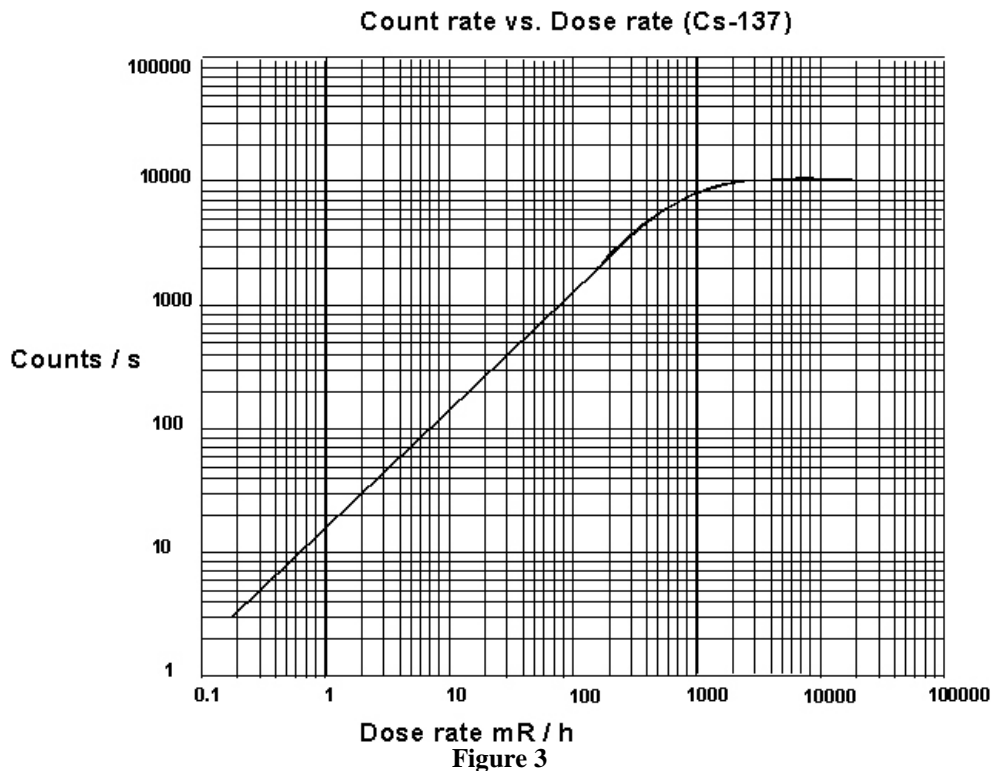

Measurement of Radiation

There are a few scales that one can use to measure radiation. Depending upon your application, one scale may be better than the others.

Radiation Measurements

Roentgen: Is the measurement of energy produced by Gamma or X-Ray radiation in a cubic centimeter of air. It is abbreviated with the capital "R". One milliroentgen, abbreviated "mR" is one-thousandth of a roentgen. One microroentgen, abbreviated "uR" is one-millionth of a roentgen.

RAD: Radiation Absorbed Dose. Original measuring unit for expressing the absorption of all types of ionizing radiation (alpha, beta, gamma, neutrons, etc) into any medium. One rad is equivalent to the absorption of 100 ergs of energy per gram of absorbing tissue.

REM: Roentgen Equivalent Man is a measurement that correlates the dose of any radiation to the biological effect of that radiation. Since not all radiation has the same biological effect, the dosage is multiplied by a "quality factor" (Q). For example, a person receiving a dosage of gamma radiation will suffer much less damage than a person receiving the same dosage from alpha particles, by a factor of three. So alpha particles will cause three times more damage than gamma rays. Therefore, alpha radiation has a quality factor of three. Following is the Q factor for a few radiation types

Radiation:	Quality Factor (Q)
Beta, Gamma and X-rays	1
Thermal Neutrons	3
Fast n, a, and protons	10
Heavy and recoil nuclei	20

The difference between the rad and rem is that the rad is a measurement of the radiation absorbed by the material or tissue. The rem is a measurement of the biological effect of that absorbed radiation.

For general purposes most physicists agree that the Roentgen, Rad and Rem may be considered equivalent.

The curie is a unit of radioactivity, its symbol (Ci). It is defined by the amount radioactive decays per second. $1\text{Ci} = 3.7 \times 10^{10}$ decays per second.

When you purchase a radioactive isotope source, it will be rate in microcuries (uCi) (one millionth of a curie).

System International (SI) of Units

The System International of unit for radiation measurements is now the official system of measurements. This system uses the "gray" (Gy) and "sivert" (Sv) for absorbed dose and equivalent dose respectively.

The conversion from one system to another is simple:

1 Sv	= 100 rem	1 rem = .01 Sv
1 mSv	= 100 mR (mrem)	1 mR = .01 mSv
1 Gy	= 100 rad	1 rad = .01 Gy
1mGy	= 100 mrad	1 mrad = .01 mGy

The SI derivative of the curie is the becquerel (Bq) (pronounced: 'be-kə-rel) which equals one decay per second.

How Much Radiation is Safe?

In the United States the U.S. Nuclear Regulatory Commission (NRC) determines what radiation exposure level is considered safe. Occupational exposure for worker is limited to 5000 mrem per year. For the general population, the exposure is 500 mrem above background radiation in any one year. However for long term, multi-year exposure, 100 mrem above background radiation is the limit set per year.

Let's extrapolate the 100 mrem number to an hourly radiation exposure rate. There are 365 days/yr x 24 hr/day equals 8760 hours. Divide 100 mrem by 8760 hours equals .0114 mrem/hr or 11.4/hr microrem. This is an extremely low radiation level. The background radiation in my lab hovers around 32 uR/hr. Am I in trouble? No. Typically background radiation in the United States averages 300 mrem/yr, or 34 microrem/hr. The NRC specifications is for radiation above this 34 urem/hr background radiation.

Notice that my lab readings are in microrad (uR/hr) and the exposure limit is given in microrem (urem/hr). I do not know what type of radiation (a, b or y) the geiger counter is reading in my lab at any particular instant, so I do not know the Q factor of the radiation and therefore can not calculate the mrem. However for general purposes I consider them the one and the same. The digital Geiger counters I use are calibrated using a Cs-137 radioactive source. Therefore the highest accuracy in reading radiation levels will be from Cs-137 sources.

Common Radiation Exposure (General Population)

Exposure Source	Dose(conventional)	Dose (SI)
Flight from LA to NY	1.5 mrem	.015 mSv
Dental X-ray	9 mrem	.09 mSv
Chest X-ray	10 mrem	0.1 mSv
Mammogram	70 mrem	0.7 mSv
Background Radiation	620 mrem/year	6.2 mSv/year

Background radiation consists of three sources; Cosmic radiation from the sun and stars. Terrestrial radiation from low levels of uranium, thorium, and their decay products in the soil, air and water. Internal radiation from radioactive potassium-40, carbon-14, lead-210, and other isotopes found inside our bodies.

Testing for Radioactive Contamination

For this test to be as sensitive as possible it is recommended that the GM tube be sensitive to alpha, beta and gamma radiation.

Geiger counters can only test for gross radioactive contamination levels that will show up above background radiation levels. Low level radioactive contamination may be effectively hidden within the natural "noise" of background radiation and not discernable using a Geiger counter. Therefore for low level radioactive contamination Geiger counters are not the proper test instruments. With this disclaimer in place, this is the procedure to test for radioactive contamination that presents a increase in the background radiation. Step one; first establish the background radiation level.

To establish background radioactivity level, record the pulses (Counts) received per minute (CPM). The greater the number of minutes you count the more accurate will be your background radiation reading.

Average the CPM reading to determine an approximate background radiation level for your area. The highest and lowest CPM count will establish your minimum and maximum CPM. These numbers will establish a baseline so that you will be able to determine if the background radiation has changed, or to detect trace amounts of radioactive materials.

If you look at the data I obtained from the Data Logger discussed later, in the Excel spreadsheet my average CPM reading, based on 298 samples, was 16 CPM. The Minimum CPM was 6 and the Maximum CPM 28.

To run a test position the probe (or Geiger counter) very close to the top surface of the material you are testing, and run the counter recording the CPM output. The longer the run obtaining CPM data, the more accurate the results.

Compare the radiation output of your sample under test to your established background radiation.

Images does not make any warranties (express or implied) about the radiation information provided here for your use. All information provided should be considered experimental. Safety and health issues and concerns involving radioactive contamination should be addressed, confirmed and verified with local and national government organizations or recognized experts in this field.

Geiger Counter Schematic Caution * High Voltage * Caution

While the Geiger counter is on (powered), the bare PC board contains exposed high voltage components and pads. Even when the circuit is turned off (power is removed) the capacitors still may hold a high voltage charge. A project box or case is recommended and available for separate purchase based on the option chosen for your kit.

The circuit is shown in figure 4. The HV section of the circuit is built around a single transistorized (TIP3055) ringing choke converter that has been around for years. This particular derivative of the circuit was designed by Sam Evans to minimize current draw. The important element in this circuit is the transformer. In this configuration, the primary winding of the transformer and the feedback winding of the transformer are arranged so that the circuit begins a sustaining oscillation when power is applied. If you checked the output of the oscillator you would find the waveform's duty cycle is symmetrical.

The primary oscillation amplitude is around 6V at 14.1kHz. This gets amplified with the large step-up ratio of the transformer and we obtain about 325V_(p-p) across the secondary. The current consumption is about 5ma. A simple voltage multiplier is used to boost up this voltage in steps to give a final DC of about 600V DC.

The high voltage output from this stage is regulated by zener diodes. Here the user can decide which zener diode regulators to use to vary the regulated DC output. There are three zener diode positions on the pc board, D8, D9 and D10. If one uses 200V zeners in each position the regulated output is 600 volts. Using 100 volt zeners in each position the regulated output is 300 volts. Using (2) 200V

zeners and (1) 100 volt zener provides 500 VDC regulated output

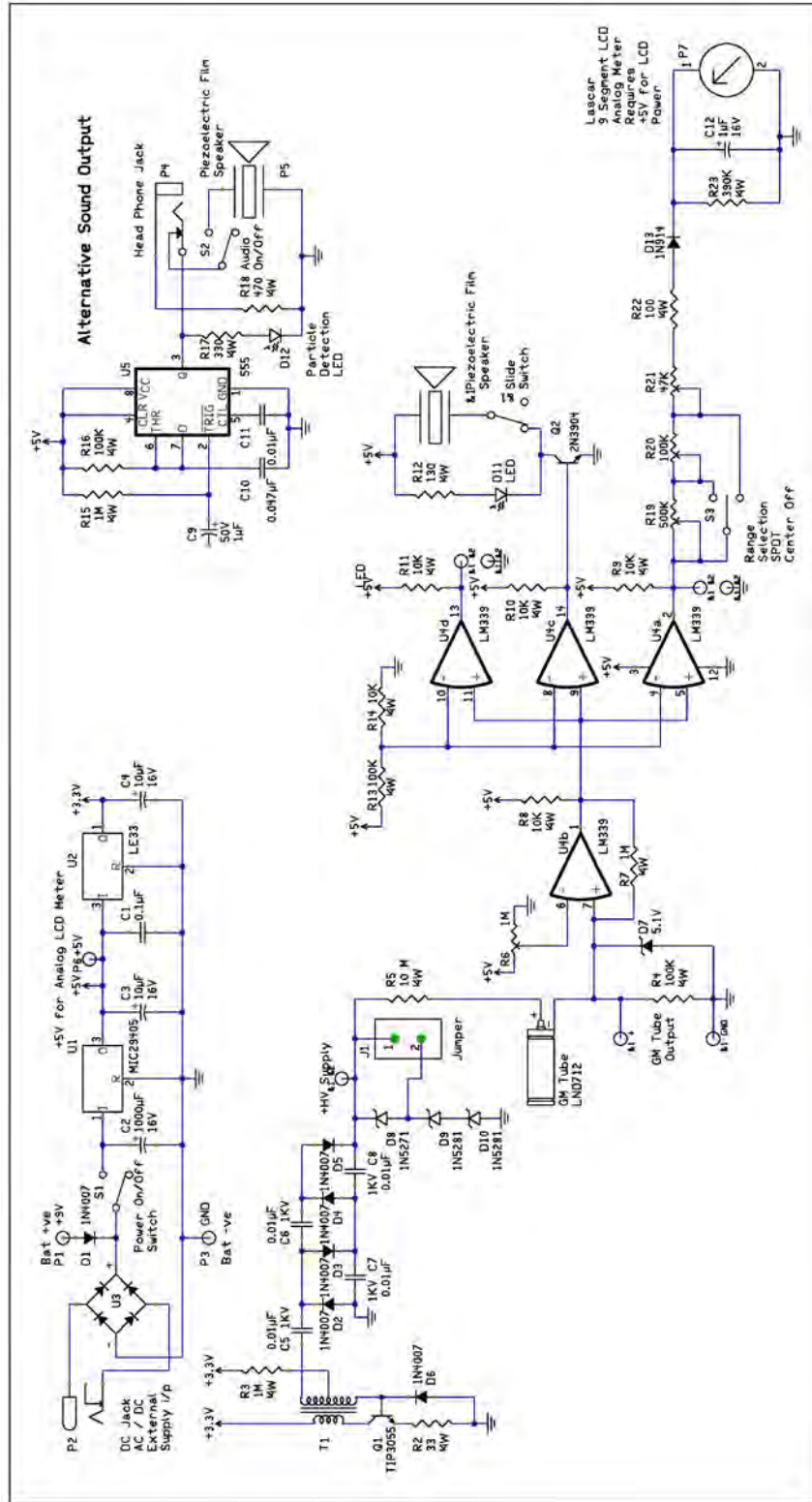

Figure 4

In the latest revision of the PC Board there is a jumper J1 that shorts out the D8 zener. By putting 200 volt zener diodes in the D9 and D10 position and a 100 volt zener in the D8 position you can change the regulated output to the GM tube from 500 VDC to 400 VDC by adding a jumper.

So its easy to vary the regulated output from 300 to 600 VDC depending upon the voltage required of their GM tube.

Assuming a 500 VDC output and a LND712 GM tube the 500-volt regulated output is fed to the anode of the GM tube through a current limiting 10 mega-ohm resistor R5. The 10 mega-ohm resistor limits the current through the GM tube and helps quench the avalanched ionization when a radioactive particle is detected.

The cathode of the tube is connected to a 1 meg potentiometer and a 100K resistor. Each time a particle is detected a voltage pulse is generated across this resistance. The pulse is fed from the wiper of the potentiometer to the inverting input to a 339 comparator.

The comparator cleans up the pulse and down streams it to the three other comparators. The output of the second comparator feeds to the base of a 2N3904 transistor. The transistor powers an LED and speaker so that each time a particle is detected the LED blinks and the speaker clicks. The other comparator outputs are available for use by the user via Screw terminals on the edge of the board.

Alternative Audio Output: To create a more pronounced click you can use the alternative audio output section. The pulse signal from the comparator is a trigger to the 555 Timer. The timer is set up in monostable mode that stretches out the pulse received on its trigger. The output pulse from the timer flashes the LED and outputs an audible click to the speaker via pin 3.

Construction

Caution * High Voltage * Caution

While the Geiger counter is on (powered), the bare PC board contains exposed high voltage components and pads. Even when the circuit is turned off (power is removed) the capacitors still may hold a high voltage charge. A project box or case is recommended and available for separate purchase based on the option chosen for your kit.

The PCB for this kit is shown in figure 5.

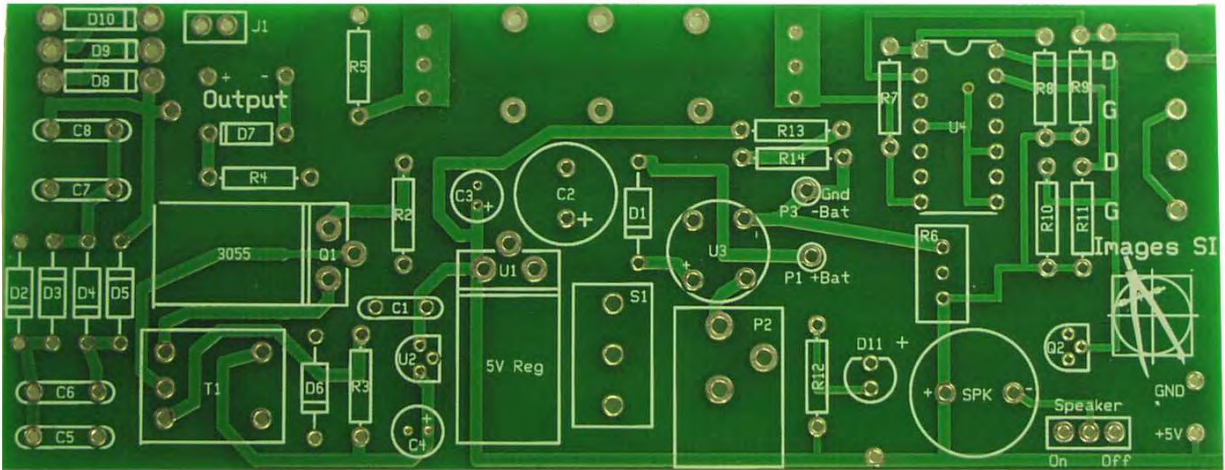

Figure 5

When using the PC board its merely a matter of mounting and soldering the components in their proper position. All the parts are outlined on the top silk screen, see figure 5.

Begin by mounting and soldering all the resistors, see figure 6.

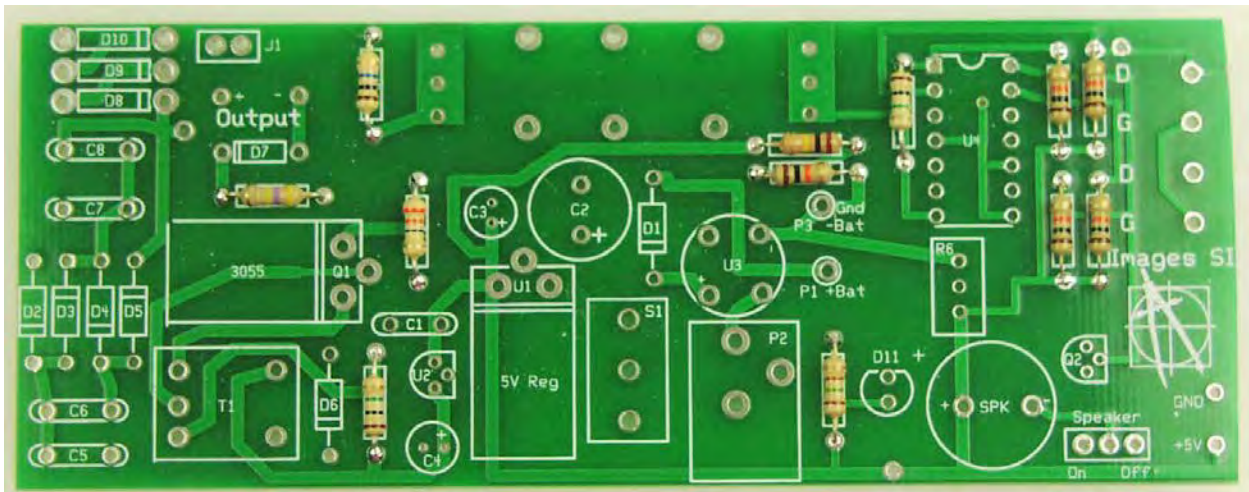

Figure 6

- R2 - 33 ohm (color code - orange, orange, black, gold),
- R3 and R7 - 1 meg-ohm (color code - brown, black, green, gold),
- *R4 - 470 K-ohm (color code - yellow, purple, yellow, gold),
- *R5 - 10 meg-ohm (color code brown, black, blue, gold),
- R8-R11 and R14 - 10K-ohm (color code - brown, black, orange, gold),
- R12 - 150 ohms (color code - brown, green, brown, gold)
- R13 - 100 K-ohm (color code - brown, black, yellow, gold)

*These resistor values will change depending upon the specific GM tube used. Default values are for the LND712 GM Tube.

Customizing circuit for GM Tube.

The two resistors R4 and R5 need to be matched to your GM tube also. R5 is the anode resistor. The anode resistor prevents too much current from passing through the tube when the tube detects a radioactive particle. This resistor can vary between 2.2 mega-ohms and 10 mega-ohms for different GM tubes. You need to read the specifications on your particular tube. The Cathode resistor is R4 and may vary between 47 K ohm to 1 mega-ohms for different GM tubes. The voltage pulse across this resistor is fed to the comparator.

Zener Diodes

Mount and solder diodes D1 through to D11. Make sure to orientate the line on the diodes with the line on the silk screen diode drawing on the printed circuit board.

D1, D2, D3, D4, D5, and D6 - 1N4007

D7 - 5.1V Zener

D8 - 100V Zener

D9 and D10 - 200V Zener (* See text)

D11 - LED

The longer lead on the LED (D11) is the positive lead. Make sure the positive lead is inserted into the pad toward the bottom of the pc board (on the round side of the silk screen LED outline). Next mount and solder the 14 pin IC socket, see figure 7.

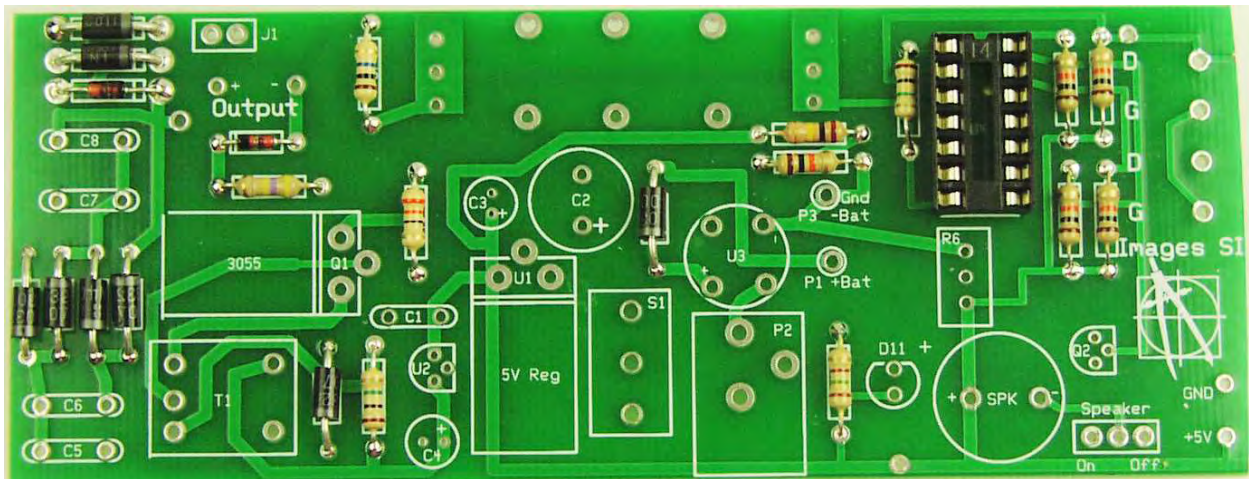

Figure 7

In addition to adjusting the resistors to the GM tube, you can also adjust the voltage to the GM tube. Depending upon the zener diodes used, you can vary the voltage between 400 and 600 volts. The zener diodes (D8, D9 and D10) to provide the regulation of the voltage delivered to the GM Tube.

The zener diodes provided with the kit are D8 - 100 volts, D9 and D10 - 200 volts. With this diode set you can vary the voltage to either 400 volts or 500 volts to the GM tube. Keeping jumper J1 open will provide 500 VDC to the GM tube. Shorting jumper J1, shorts out diode D8 and provides 400 VDC to the GM tube.

If you required 600 VDC, diodes D8 to D10 ought to be made 200 zener diodes. Keeping jumper J1 open provides 500 VDC to the GM tube. Shorting jumper J1, shorts out diode D8 and provides 400 VDC to the GM tube.

Next install the regulator 7805 and the 3055 (or H1061) transistor. Insert components on the pc board and bend them into place BEFORE soldering, see figure 8. Mount and solder capacitors :

C1 - 0.1 μ F

C2 - 330 μ F-16V, (can vary between 220uf and 1000uf)

C3 and C4 - 10 μ F-16V,

C5, C6, C7 and C8 - 0.01 μ F - 1KV.

Mount and solder mini-step-up transformer T1.

Mount and solder the 14 pin IC socket U4.

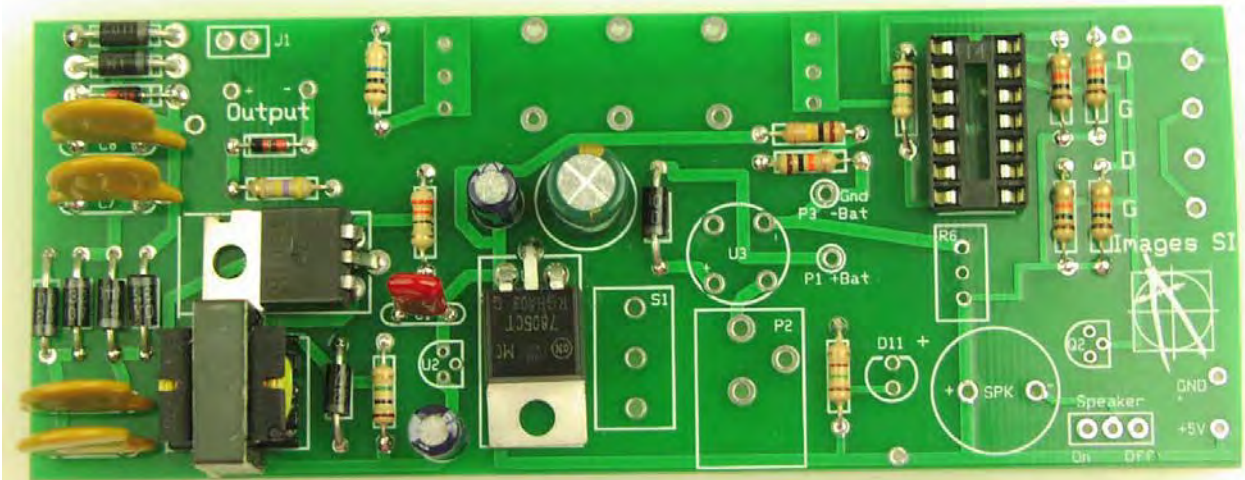

Figure 8

Finishing Board Construction

Mount and solder U2 and Q2. Making sure their profile matches the silk screen outline of these parts before soldering. Next mount and solder the bridge rectifier U3. Align the positive terminal of the bridge rectifier with the + pad on the pc board. Mount and solder the P2 external power supply connector. Mount and solder S1 toggle switch. Mount and solder on-off slide switch for the speaker. Next mount and solder the piezoelectric speaker. The long lead on the speaker is positive and should be inserted into the + pad on the pc board. Mount and solder the 1-meg-ohm potentiometer in the R6 position on the PC board. Next solder the 9V battery clip to the PC board. The red wire is soldered to the P1 + Bat pad. The black wire is soldered to P3 -Bat pad. Finish the board by mounting and soldering the two pin header in the J1 position. Your board should appear as in figure 9.

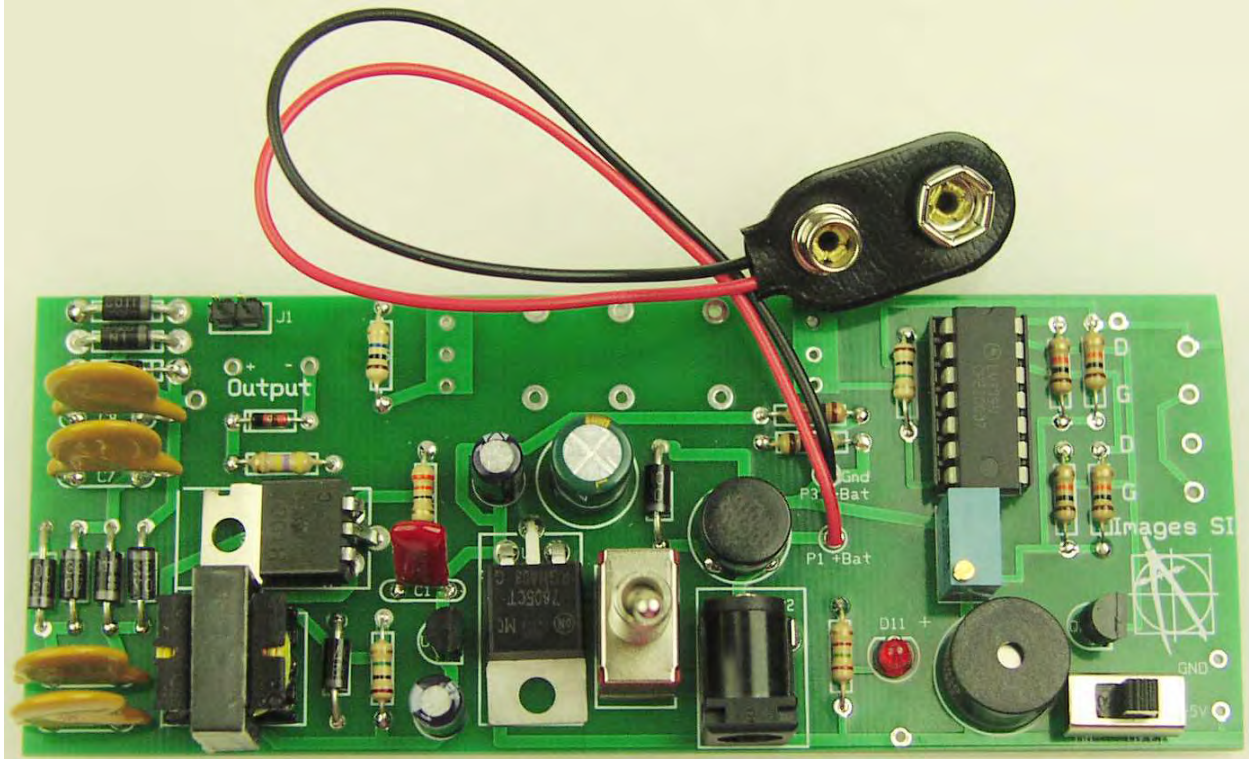

Figure 9

Insert the LM339 into the 14 pin socket., see figure 10. Align notch on IC as shown in the figure 10.

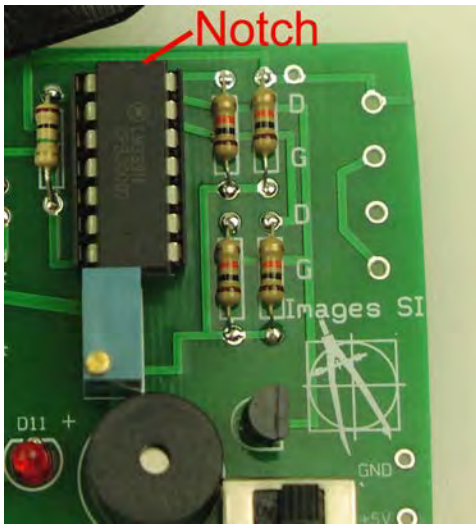

Figure 10

Attaching GM Tube(s)

With the board completed its time to attach the GM tube. The Geiger Muller tubes have two leads. For the LND 712 the lead connected to the metal sides of the tube is the ground. This is soldered to the (-) GM terminal on the PC board, see figure 11, left circuit. The center terminal of the GM tube has a removable solder lead. Remove the lead, solder 1.5" of wire to and. Reattach the lead to the center

terminal of the GM tube. Take the opposite end of the wire and solder to the (+) GM terminal on the PC board.

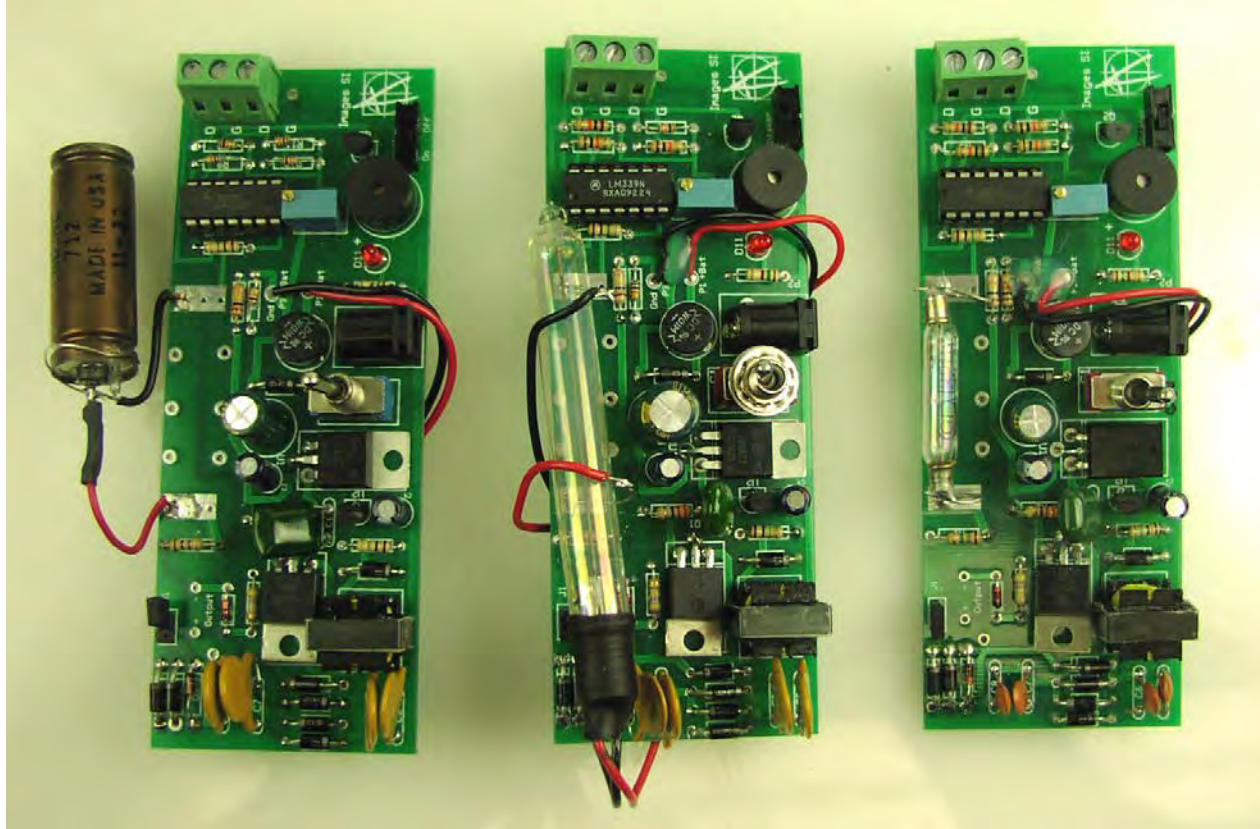

Figure 11

The 712 Geiger Mueller tube's front mica window is delicate and should be protected by a screen. An open screen will protect the tube and at the same time allow the detection of alpha particles to pass through the front mica window.

The large and small glass GM tube in center position in figure 11 requires an anode resistor (R5) of 3.3 mega ohms and a cathode resistor (R4) of 470K ohms. The regulated voltage required for these tubes is 400 volts DC. You need to adjust the zener diodes in the regulator section to provide this voltage, by shorting the jumper J1.

The small GM tube, the right hand circuit in figure 11 may be mounted to the PC board and strapped down using a few pieces of scrap wire. After securing with a wire a small amount of glue or epoxy can be dabbed on the wire tube assembly for added support. Each end of the GM tube has a wire soldered to its end and the wire soldered into one of the side holes.

In my tests, the larger of the glass GM tube is more sensitive to gamma radiation than the smaller glass gm tube due to its greater detection volume and area.

Radioactive Sources

Uranium ore is available from a number of sources including e-bay. See suppliers list:

A more reliable source is to purchase a radioactive source. Small amounts of radioactive materials are available for sale encased in 1 inch diameter by ¼" thick plastic disks. The disks are available to the general public license exempt. This material outputs radiation in the micro-curie range and has been deemed by the U.S. Federal government to be license free and safe.

The cesium-137 is a good gamma ray source. The cesium 137 has a half-life of 30 years.

Adjusting sensitivity of Geiger counter- Check Out

You will need to adjust the sensitivity of the Geiger counter. This is accomplished using potentiometer R6. Step one, turn on the Geiger counter. Step two, make sure the speaker switch is turned on. Step three, if you have a radiation source bring it very close to the GM tube. Step four, adjust R6 until you hear clicking and see the LED blink. Each radioactive particle detected will cause the Geiger counter to click and flash the LED. Depending upon the sensitivity of your GM tube, each click represents the detection of one of the radioactive rays; alpha, beta or gamma.

If you do not have a radioactive source background radiation, from natural sources on earth and cosmic rays will cause the Geiger counter to click. In my corner of the world I have a background radiation that triggers the counter on average 16 Counts Per Minute (CPM). Adjust R6 until you hear approximately 16 counts per minute. While the average CPM in my area is 16, the actual counts vary between a min count of 6 CPM and a maximum of 28 CPM.

The clicking can get annoying when performing some nuclear experiments so an on-off speaker switch is available to turn off the speaker.

ACCESSORIES:

In this section I will look at the accessories one use with this Geiger Counter.

Data Loggers - Digital Output

This Geiger Counter has two digital outputs that outputs a +3-5V pulse with each detection of a radioactive particle.

Analog /Digital Meter

A electronic analog/ digital analog meter adds versatility to the Geiger Counter device by providing a visual indication of the intensity of the radiation field.

Calibration of Geiger Counter using Analog/Digital Meter

We can use a simple procedure to get a ball park calibration for the electronic Analog/Digital meter. The difficulty in calibrating the meter to any Geiger counter is difficult because of the variables in play. The GM Tubes tube's response can vary +/- 20 %. The strength of the uncalibrated radioisotope source can vary +/- 20% from its rated value. In addition to variance in our electronic components. All these factor affect accuracy. With this being said, we can check the ball park accuracy of our meter. If your meter is adjustable, you can use the information to better approximate the radiation levels.

This calibration procedure uses a 10 uCi CS-137 source, see parts list. The source is held at specific distances from the GM tube for each range and the approximate radiation value is given in the chart below.

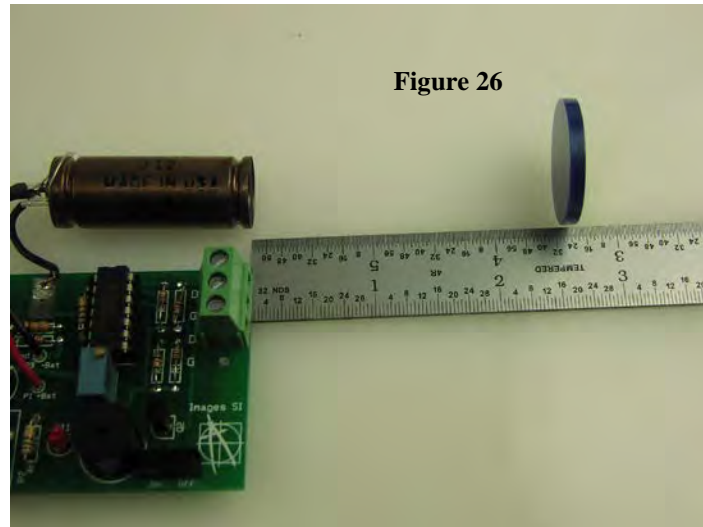

GM Tube	GMT-01 (LND712)	GMT-02	GMT-06
0-1 mR/hr	6"	6.5"	0.5"
0-10 mR/hr	2.5"	1.6"	0.25"
0-100 mR/hr*	0.5"	0.25"	0.0"

The procedure is the same for the GMT-02,

The procedure is the same for the GMT-06, however this tube has not been tested extensively enough.

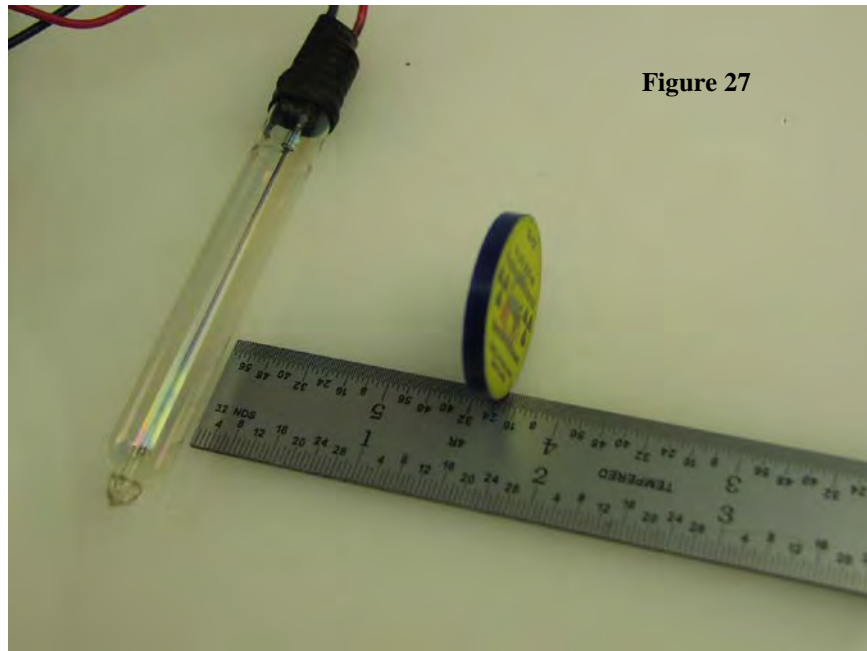

Figure 27

Once you have your Geiger Counter calibrated you may want to consider placing the circuit inside a case to protect yourself from the high voltage traces and pads on the PCB. , see figure 28.

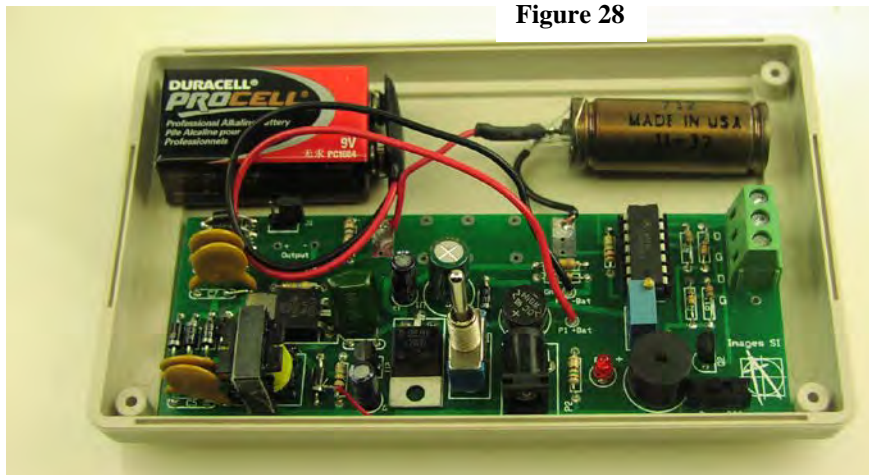

Figure 28

I

Parts List

- (1) PCB Printed Circuit Board
- (4) 0.01 μ F 1KV C5 C6 C7 C8
- (1) 0.1 μ F C1
- (2) 10 μ F 16V C3 C4
- (1) 330 μ F 16V C2 * see text

(6) 1N4007 D1, D2, D3, D4, D5, D6
 (2) 200V Zener D9 D10 (* See text)
 (1) 100V Zener D8
 (1) 5.1V Zener D7
 (1) LED D11
 (1) PJ102B P2
 (1) 2N3904 Q2
 (1) TIP3055 Q1 (alternate transistor H1061)
 (2) 1meg ¼W R7, R3
 (1) 10 Meg ohms ¼W R5 * See text
 (1) 33 ohms ¼W R2
 (1) 100 K ohms ¼W R13,
 (1) 470K ohm 1/4 W R4 * See text
 (1) 100 ohms ¼W R12
 (5) 10K ¼W R8, R9, R10, R11, R14
 500K P36W R6 (Alternative 1 mega-ohm)
 Switch Toggle S1
 Switch Slide S2
 (1) Transformer T1
 Full-Wave Bridge Rect. U3
 LE33 TO92R U2
 LM339 DIP14 U4
 (1) 14 pin IC socket
 7805 TO220 U1
 SPK Piezo speaker
 (1) 9V battery cable
 (1) 2-pin headers J1
 (1) 2-pin jumper

Components that are sold separately:

GMT-01	\$99.95
GMT-02	\$74.95
GMT-06	\$ 49.95
Mini Step-up transformer	\$ 12.00
Geiger Counter PCB	\$ 10.00

Radioactive Sources:

Uranium Ore	\$39.95
CS-137 Source (5 uCi)	\$84.00 * Drop shipped from different location
CS-137 Source (10 uCi)	\$125.00* Drop shipped from different location

Order from:

Images Company
 Staten Island NY 10312
 718-966-3694 Tele

718-966-3695 Fax

on the Internet at:

<http://www.imagesco.com>

Helpful Links

U.S. Nuclear Regulatory Commission

<http://www.nrc.gov/>

CDC - Center for Disease Control maintains a radiation emergency web site:

<http://www.bt.cdc.gov/radiation/index.asp#clinicians>

Health Physics Society

<http://www.hps.org>

U.S. Environmental Protection Agency

<http://www.epa.gov/radiation>