

High Voltage Flyback Generator Kit

Images Scientific Instruments Inc. HVPS-02FB



High Voltage Flyback Transformer Kit

This kit generates high voltage using a fly back transformer.

The High Voltage generator kit can be used for many high voltage experiments.

Energizing neon gas tubes, fluorescent lamps, Geissler tubes, plasma balls, kirlian photography, etc



See high voltage safety guide pg 3

Manual and Construction Booklet For High Voltage Flyback Transformer Generator Kit

Table of Contents

Safety Guidelines.....	3
Warranty.....	4
High Voltage Power Supply.....	5
How Circuit Works.....	5
Schematic.....	6
Construction.....	7
Usage.....	8
What is an Ion.....	10
Generating Ions.....	10
More Fun Things to Try.....	11
Parts List.....	12
Appendix A.....	13
Notes.....	14

Important Safety Warning

This is a high voltage power supply that is intended for use by adults. Children should not build or operate this kit. This kit is not intended for children!

Assembly of this kit requires high-temperature soldering and the use of sharp edged components and cutting tools. Some included components may become hot, leak, or explode if used improperly. Images strongly recommends that you wear safety glasses when building or working with any electronic equipment.

High voltage discharges and shocks can cause injury and/or death. Additionally high voltage electricity as generated by this assembled kit can cause damage to property. SI Images disclaims liability for damage or injury caused by the use of the Fly Back Generator Kit. By using this product, you agree not to hold Images liable for any injury or damage related to the use or to the performance of this product. This product is not designed for, and should not be used in, applications where the malfunction of the product could cause injury or damage.

High Voltage Safety

The High voltage Generator produces 15 kV (15,000 volts). This is extremely high voltage and may be lethal. The current our high voltage power supply can deliver is approximately 600 uAmps (0.6 mA). A person's health has an impact on the amount of current that would be lethal to any particular person. So please follow the safety guideline provided and do not use if you have a health condition which makes you susceptible to shocks.

An electrical shock can cause you to jump, move or fall and can thereby cause a secondary injury, unrelated to the electric shock itself. Take the following precautions and treat all high voltage power supplies with the respect they deserve.

Follow these simple guidelines and rules.

- 1) Keep one hand in your pocket. Only use your other hand to work with the high voltage equipment. This reduces the probability of accidentally passing high voltage current across your heart from hand to hand.
- 2) Set up your work area away from possible grounds that you may accidentally contact. Keep your work area neat and clean to easily identify high voltage wires and grounds.
- 3) Be sure the floor is dry and wear preferably rubber-soled shoes.
- 4) Prove to yourself the high voltage power supply is off, by unplugging the device's electrical power cord. Don't trust power switches that could be hit or pressed and accidentally turned on.
- 5) Discharge all high voltage before working on the device. This means attaching a wire to the circuit ground and touching the high voltage output terminal with the grounded wire. This will dissipate any stored high voltage charge.
- 6) Do not work on high voltage apparatus when you are tired and not alert even if it means a delay.
- 7) Never charge a capacitor using the high voltage power supply. Even small high voltage capacitors can deliver lethal current!
- 8) Never leave the generator plugged in while unattended.
- 9) Do not use the generator if you have a heart condition, are pregnant, or have any condition or health issue that might render you susceptible to electrical shocks.
- 10) Keep your mobile phone, personal computer, tablet, or other personal devices at least ten (10) feet away from the generator as they may be permanently damaged.



- 11) You must furnish your own power source for this kit. Never use an incompatible or incorrect power source as it may result in the generator overheating or fire.
- 12) Use safety precautions when soldering and assembling the kit.
- 13) Do not use the kit except as assembled per the instructions contained herein.
- 14) Do not add, substitute or remove components to the kit assembly.

WARRANTY

IF YOU DO NOT AGREE TO THESE CONDITIONS, YOU SHOULD NOT PURCHASE THE PRODUCT. IN NO EVENT SHALL IMAGES SI BE LIABLE FOR ANY INCIDENTAL, SPECIAL, CONSEQUENTIAL OR PUNITIVE DAMAGES, OR FOR ANY COSTS, ATTORNEY FEES, EXPENSES, LOSSES OR DELAYS ALLEGED TO BE AS A CONSEQUENCE OF ANY DAMAGE TO, FAILURE OF, OR DEFECT IN ANY PRODUCT INCLUDING, BUT NOT LIMITED TO, ANY CLAIMS FOR LOSS OF PROFITS. SOME STATES DO NOT ALLOW THE EXCLUSION OR LIMITATION OF INCIDENTAL OR CONSEQUENTIAL DAMAGES, SO THE ABOVE LIMITATION OR EXCLUSION MAY NOT APPLY TO YOU. THIS WARRANTY IS EXCLUSIVE AND IN LIEU OF ALL OTHER EXPRESS WARRANTIES, WRITTEN OR ORAL. TO THE EXTENT PERMITTED BY LAW, SI IMAGES DISCLAIMS ANY IMPLIED WARRANTIES, INCLUDING WITHOUT LIMITATION ANY IMPLIED WARRANTY OF MERCHANTABILITY. OR FITNESS FOR A PARTICULAR USE OR PURPOSE; TO THE EXTENT SUCH DISCLAIMER IS NOT PERMITTED BY LAW, SUCH IMPLIED WARRANTIES ARE LIMITED TO THE DURATION OF THE APPLICABLE.

EXPRESS WARRANTY AS DESCRIBED ABOVE. SOME STATES DO NOT ALLOW LIMITATIONS ON HOW LONG AN IMPLIED WARRANTY LASTS, SO THE ABOVE LIMITATION MAY NOT APPLY TO YOU, THIS WARRANTY GIVES YOU SPECIFIC LEGAL RIGHTS, AND YOU MAY ALSO HAVE OTHER RIGHTS WHICH VARY FROM STATE TO STATE.

High Voltage Power Supply

The high voltage power supply may be used for a variety of high voltage experiments:

May be used to light; Geissler Tubes, Neon Tubing, Fluorescent lamps

High Voltage Ion Generator

Kirlian Photography

Plasma spheres—Or make a plasma sphere out of a small clear appliance bulb.

How it Works

Look at the schematic on page 6.

When power is applied to the circuit, the current through resistor R1 and feedback winding (14T) coming in to the base of the transistor and puts the transistor into conduction.

This initiates current through the primary windings (16T) creating a magnetic field in the transformer and inducing a current and high voltage spike on the secondary windings (4,200T output) of the flyback transformer. At the same time the magnetic field reversed the polarity in the feedback coil (14T), turning off the transistor. With the transistor turned off the current is cut which causes the magnetic field in the core to collapse, keeping the current in (14T) feedback winding reversed.

After magnetic field in the transformer dissipates, the transistor is again pushed into conduction through the R1 resistor and circuit operation repeats. High voltage is generated when the oscillation is adjusted to a resonance frequency of the transformer which in this circuit is approximately 22KHz.

Flyback circuit diagram

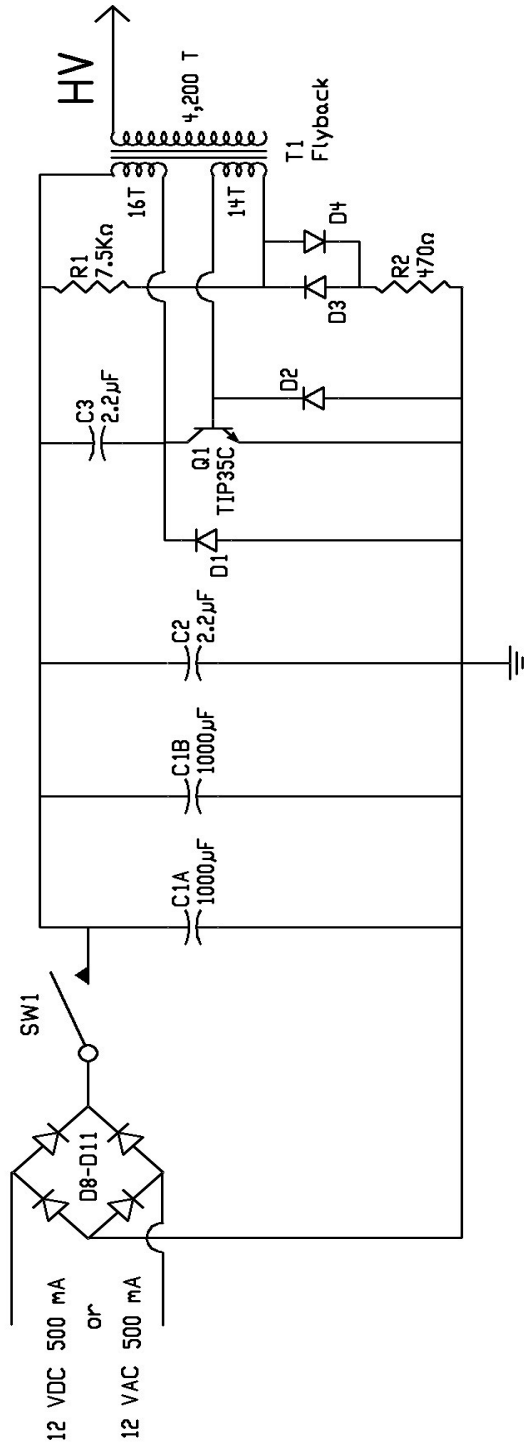

Construction

Begin construction by attaching the TIP35C transistor to the aluminum heat sink, see figure 1, using the 6-32 machine screw, nut and #6 split lock washer.

Figure 1

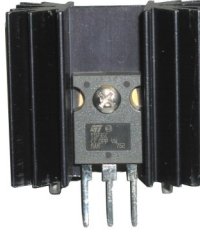

Next, solder the transistor to the pcb board and solder the mounting pins of the heat sink to the pcb, see figure 2.

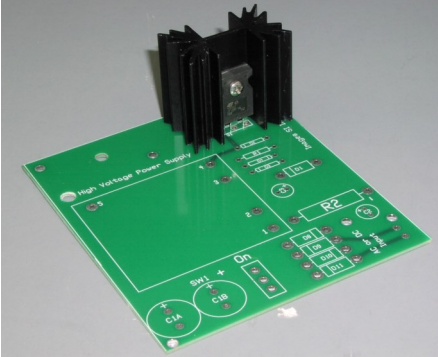
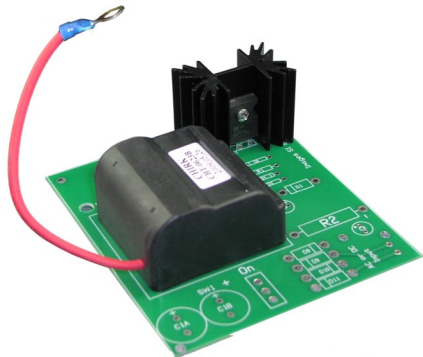

Figure 2

The fly back transformer is soldered to the PC board. The ring terminal on the HV wire output of the fly back transformer. See figure 3

Figure 3



Locate P1 and P2 on the PCB. Insert a small piece of wire into the top 2 holes at each position and solder into place (see figure 4).

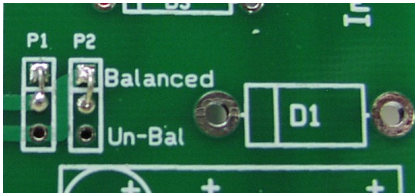

Figure 4

Next mount and solder the following components; C1A and C1B, 1000 uf 50V capacitors, SW1, on-off toggle switch, D8-D11 (diodes 1N5402/01), D2,D3 and D4 (FR102) D1 (FR204) making sure the band on the diodes are oriented properly according to the silk screen outline for the diodes, resistor R1, 7.5K ohm and power resistor R2 (470 ohms). Finish up by mounting C2 (2.2 uF 100V) and C3 (2.2 uF 250V) capacitor.

The C3 leads are bent as shown in figure 5 and mounted as shown in figure 6. C3 does not have a polarity and may be mounted with either lead in the + pcb hole.



Figure 5

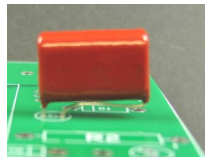

Figure 6

Finish the circuit by mounting and soldering the green two terminal block. Next mount the four clear plastic feet on the bottom of the pcb.

Usage:

To power the high voltage generator you need to attach a power supply to the two terminal block. We recommend a 12 VAC 500 mA or 12 VDC 500 mA power supply. Attach power supply wires, any polarity to the terminal blocks and secure the wires with the top screws. Turn on the high voltage generator using the on-off switch.

Pictures to the right are shown with optional discharge ball (not included).

Lighting a small Geissler tube.

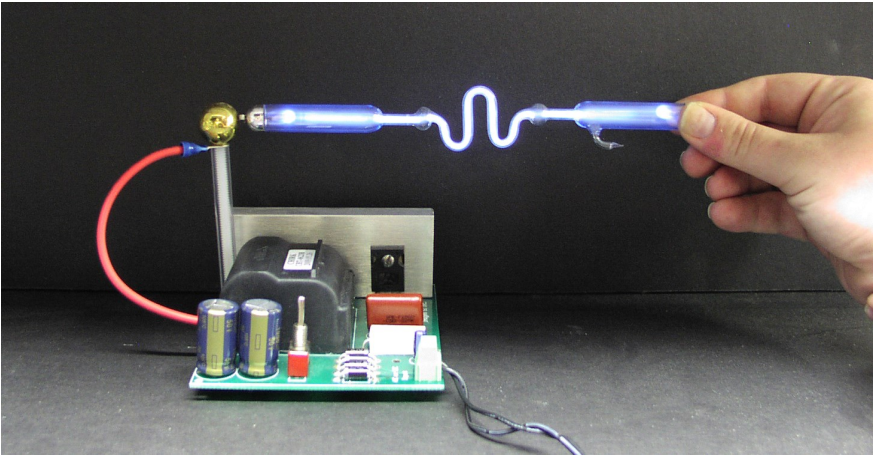

Lighting a small fluorescent tube

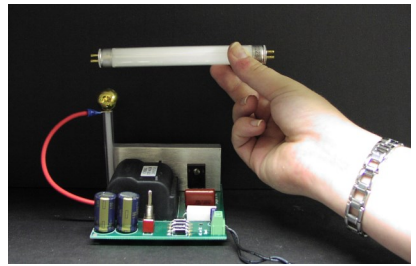
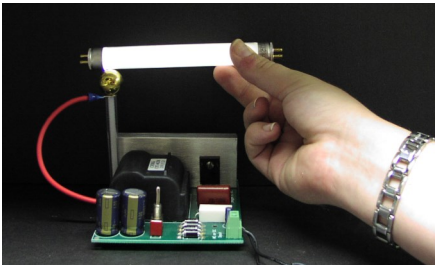

Turning a small appliance bulb into a Plasma Sphere.

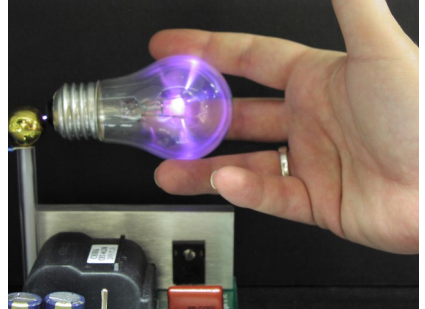
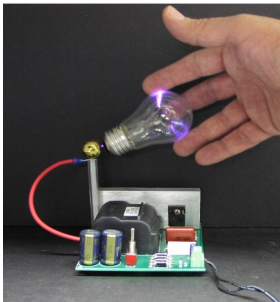

What's an Ion?

An ion is an atom or molecule that is no longer electrically neutral, it has become unbalanced electrically. The way it becomes unbalanced is by the loss or gain of a positive or negative charge. When this happens the atom (or molecule) turns into an ion that is either positively or negatively charged.

So an oxygen atom (or molecule) that acquires an free electron becomes a negatively charged ion. If however the oxygen atom loses an electron it becomes a positively charged ion.

Generating Ions

There are a few ways ions are generated; radioactivity, high temperatures, UV light or high voltages. We will focus on how high voltage can generate ions.

When dealing with high voltages, the shape of a conductor has an impact. For instance a sphere will hold a high voltage charge. While a sharp point bleeds ions into the atmosphere. This property is used to generate air ions in commercial ion and ozone generators.

To generate ions using the Plasma generator you need to connect a sharp point to the high voltage ring terminal. Be careful, a spark from the plasma generator can jump

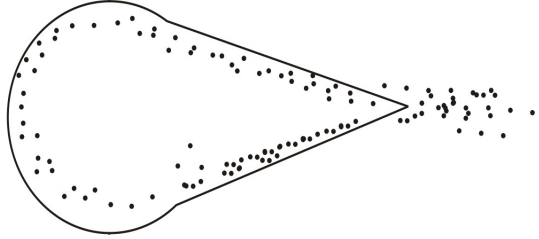
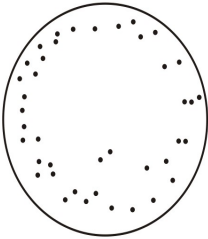

Effect of Shape on Charge

further from a sharp point than a sphere.

More fun things to try:

William Betty has a number of ion experiments to perform on his website:
<http://amasci.com/freenrg/iontest.html>

More experiments:

Visit

<http://www.imagesco.com>

Parts List

- 1 Transistor TIP35C (Q1)
- 1 PC mount Toggle Switch SW1
- 1 2.2 uf 100V capacitor (C2)
- 1 2.2 uf 250 V capacitor (C3)
- 2 1000 uf capacitors (C1A and C1B)
- 1 FR204 Diode (D1)
- 3 FR102 Diode) (D2, D3, and D4)
- 4 1N5401/02 diodes (D8-D11)
- 1 7.5K ohm resistor (R1)
- 1 470 ohm power resistor (R2)
- 1 Two position terminal block
- 1 Flyback transformer (with ring terminal)
- 1 Printed Circuit Board

Hardware:

- 4 Plastic stick-on feet
- 1 6-32 x 7/8" machine screw
- 1 6-32 x 1/4" machine screw
- 2 6-32 nut
- 1 Aluminum heatsink

Option Power Supply (not included with kit)

12 VDC 500 mA wall transformer power supply with wires for connecting to PC Board

PN# ACA-12VDC-MWW \$9.95

12 VDC 500 mA wall transformer power supply with 2.5 mm connector.

PN# ACA-12VDC-MWP \$13.95

Appendix A

Determining Resistor Values:

Resistor values are read using the color bands on the body of the resistor. The first band is the one nearest the end of the resistor. Start reading from this band. The first band represents the first significant number, the second band, the second significant number and the third band is the multiplier. If the third band is gold or silver this indicates a multiplier value of .1 or .01 respectively.

Color Value Multiplier

Black	0	1
Brown	1	10
Red	2	100
Orange	3	1000
Yellow	4	10000
Green	5	100000
Blue	6	1000000
Violet	7	10000000
Gray	8	100000000
White	9	1000000000

Tolerance (%)

Gold	5%
Silver	10%
No Band	20%

Example: A resistor with the following color bands Red, Red, Orange, Silver

1st Number Red = 2

2nd number Red = 2

3rd Number Orange = 3 multiplier (number of zeros) that equals 1000

Silver = 10%

Putting it all together:

Red Red Orange Value Tolerance

$$2 \ 2 \ x \ 1000 = 22,000 \text{ ohms } +/- \ 10\%$$

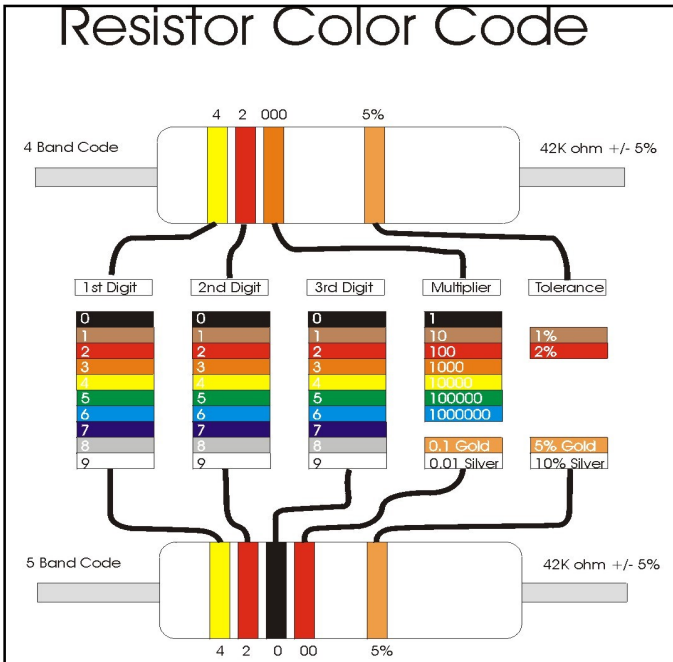

Notes:

**Images Scientific Instruments Inc.
109 Woods of Arden Road
Staten Island NY 10312
718.966.3694 tel
718.966.3695 fax
<http://www.imagesco.com>**